

# BIOBOX Double front model

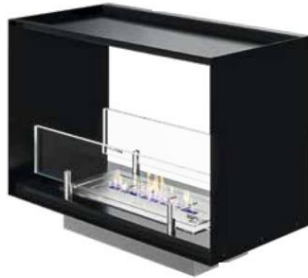

BIOsteelBOX

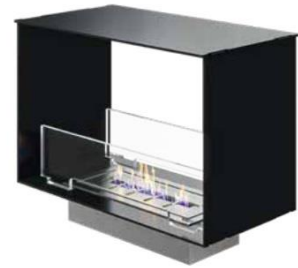

BIOaluBOX

Experience the refined sophistication of the BIOBOX double front bio-fireplace. This exquisite piece boasts a sleek matte black finish and a premium manual ARTFLAME burner, making it an eye-catching focal point for any room. The room divider design provides a seamless partition, ensuring a unique and versatile aesthetic that perfectly complements your interior. Enhanced by a floating glass screen, this bio-fireplace not only offers warmth but also a touch of elegance to your space. Available in durable powder-coated black steel or aluminium, and featuring a range of customizable options, the BIOBOX bio-fireplace can be tailored to reflect your personal style and seamlessly integrate into your home.

## BIOBOX technical data

Double front model	700	800	900	1000	1100	1200	1300	1400	1500
Dimensions in mm (L x D x H)	700 x 450 x 350	800 x 450 x 350	900 x 450 x 350	1000 x 450 x 350	1100 x 450 x 350	1200 x 450 x 350	1300 x 450 x 350	1400 x 450 x 350	1500 x 450 x 350
Artflame burner size	400	500	600	700	800	900	1000	1100	1200
Burner tank size	1,6L	2,0L	2,4L	2,8L	3,2L	3,6L	4,0L	4,4L	4,8L
Fuel efficiency in hours	<6 h	<6h	<6h	<6h	<6h	<6h	<6h	<6h	<6h
Amount of ethanol combusted at maximum opening /hour	0,26L/h	0,33L/h	0,40L/h	0,46L/h	0,53L/h	0,60L/h	0,66L/h	0,73L/h	0,80L/h
Maximum heat at maximum opening /hour	2.0kW/h	2,5kW/h		3.6kW/h	4,1kW/h	4,6kW/h	5,1kW/h	5.7kW/h	6,2kW/h
Net weight without bioethanol	10,0 kg	11,0 kg	12,0 kg	14,0 kg	16,0 kg	18,0 kg	20,0 kg	22,0 kg	24,0 kg

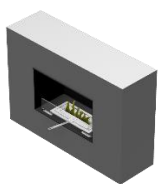

FRONT

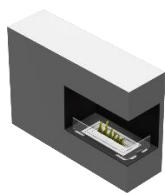

LEFT/RIGHT CORNER

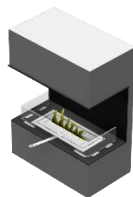

DOUBLE CORNER

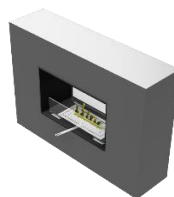

DOUBLE FRONT

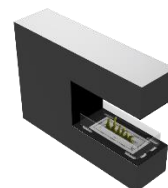

ROOM DIVIDER

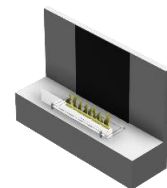

PRL

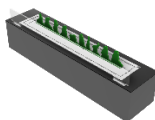

ISLAND



EASY ASSEMBLY



INDUSTRIAL DESIGN



FLAME CONTROL



FUEL EFFICIENCY



SECURE COMBUSTION CHAMBER

## BiosteelBOX Double front model drawing

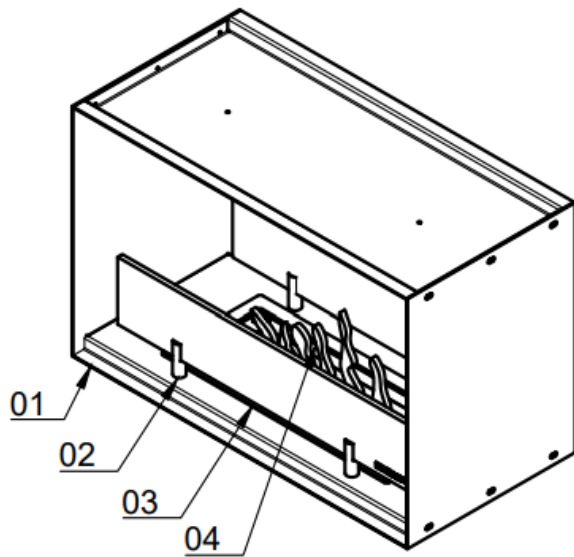

### Burner color

- Enamel coated black
- Stainless steel

### Frame color

- Powder coated black
- Custom color from the RAL palette

### Glass holder

- Easy simple slider pro

### Features

- Log set tray
- Reflecting glass

1. **Frame:** BiosteelBOX Double front model frame made out of 2mm sheet metal which is powder coated rough black (RAL 9005), optional to coating in any RAL palette colour
2. **Glass holder:** The BiosteelBOX is equipped with our easy-simple slider
3. **Glass:** 10mm transparent, tempered Optiwhite glass
4. **Burner:** Manual burner Artflame is available in 9 sizes ranging from 400 to 1200mm by width

## BioaluBOX Double front model drawing

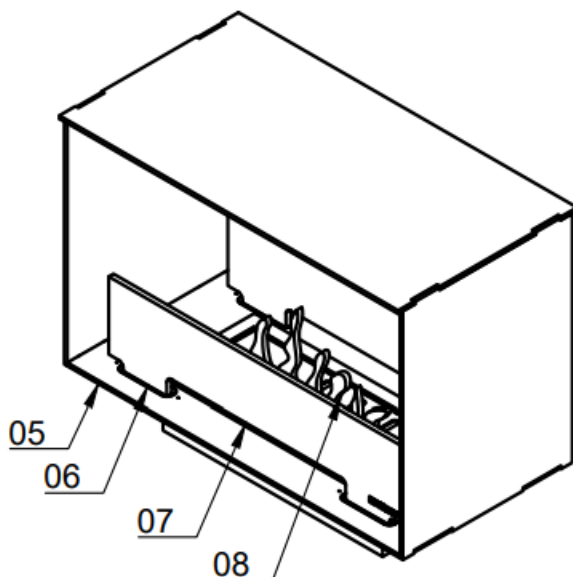

### Burner color

- Enamel coated black
- Stainless steel

### Frame color

- Powder coated black
- Custom color from the RAL palette

### Glass holder

- Easy simple slider pro
- Concealed latches NEO pro
- Quarter turn hinge
- Multipoint fastner

### Features

- Log set tray
- Reflecting glass

5. **Frame:** BioaluBOX Double front model features a seamless frame made out of 6 mm aluminium which is powder coated rough black (RAL 9005), optional coating in any RAL palette colour.
6. **Glass holder:** The BioaluBOX comes with several glass holder options: Easy simple slider pro, Concealed latches, Quarter turn hinge and multi point fastener (for more information please see our glass holder leaflet)
7. **Glass:** 10mm transparent, tempered Optiwhite glass
8. **Burner:** Manual burner Artflame is available in 9 sizes ranging from 400 to 1200mm by width